

VFS101 Pilot's Guide



VFS101-PMAN, Revision D

Revision History

Date	Revision	Description
4/27/2009	A	Initial Release
4/27/2009	B	Revised to correct page numbering
5/29/2009	C	Revised based on DER comments
7/20/2009	D	Revised based upon FAA Flight Test comments.

Table of Contents

Preface.....	(i)
1.0 Introduction.....	1
1.1 Operating Limitations.....	1
2.0 Operational Overview.....	2
3.0 VFS101 Interconnect Diagram.....	3
4.0 Getting Started.....	4
4.1 Cautions.....	4
4.2 Pilot Qualification Procedure.....	4
4.3 Activating a Direct-To Waypoint.....	4
4.3 Entering and activating a flightplan.....	6
5.0 Detailed Functional Description.....	9
5.1 VoiceFlight Activation Switch (VAS).....	9
5.2 ICAO Spelling Alphabet.....	10
5.3 Direct-To.....	10
5.4 Waypoint Entry.....	11
5.5 Error Correction.....	12
5.6 Starting a new FlightPlan.....	12
5.7 Victor Airways.....	13
5.8 Advanced Editing.....	14
6.0 Troubleshooting.....	15
7.0 Settings and Maintenance.....	16
7.1 Volume Adjustment.....	16
7.2 Updating the Navigational Database.....	17
7.3 Configuration Display Mode.....	18
8.0 Limited Warranty.....	20
Appendix A: Packing List.....	21
Appendix B: VFS101 Aural Messages.....	22
Appendix C: VFS101 Title Line Messages.....	23

Preface

This manual provides detailed instructions for the VFS101 Speech Recognition system. Please carefully review the complete manual and familiarize yourself with the system before attempting to use the VFS101 in flight.

GARMIN is a registered trademark of GARMIN, Ltd. and is not affiliated with VoiceFlight Systems, LLC in any way.

1.0 Introduction

The VoiceFlight VFS101 is a revolutionary speech-recognition system that allows pilots to rapidly enter navigational waypoints using their voice. The system provides accurate speech recognition, and nearly instantaneous response, for the great majority of pilots and flight environments. Voice entry of complex flightplans can be performed approximately ten times faster than is possible with conventional knob-twisting. The system is speaker independent and operates without any type of “enrollment” or tuning before use.

For routine flight operations, the VFS101 provides convenient, “hands-free” entry of Direct-To waypoint destinations directly into the aircraft's primary Garmin GNS430/530 GPS unit. For safety, an audio read-back of the intended waypoint is presented for confirmation before the new destination is activated.

The VFS101 also provides the capability to enter complex flight plans using speech commands. The system typically recognizes waypoint entries faster than the pilot is able to (clearly) speak them. In addition to rapid entry of multiple waypoints, the system performs automatic expansion of Victor airways, also provided via voice entry.

Flightplan #19 in the primary GPS's catalog of stored flightplans is reserved for use by the VoiceFlight system. New flightplans are safely entered here without risk of affecting active navigation of the aircraft. The flightplan's title line is continually updated to display new waypoints as they are added to the flightplan and to display error messages describing any problems that are encountered.

A suite of voice commands are available for editing the flightplan, to correct errors, or accommodate routing changes. The context of editing operations is displayed on the flight plan title line. To avoid unexpected operations, manual activation is required to begin navigation of the completed flight plan.

The VFS101 system does not alter or interfere with manual operation of the GPS units in any way. If the pilot experiences difficulties or confusion while utilizing the VFS101, conventional manual operations are readily available.

The VoiceFlight Activation Switch (VAS) is conveniently mounted on the pilot yoke and is activated by the pilot when speech commands are provided to the VFS101. The VFS101 will not recognize speech, or transmit updates to the GPS units, unless the VAS is depressed.

1.1 Operating Limitations

Each individual pilot must complete the Pilot Qualification procedures described in Section 4.2 before attempting to use the VoiceFlight unit for actual in-flight navigation. This is to ensure the VFS101 is able to safely recognize the pilot's voice, and that the pilot is familiar with the VFS101's operation.

2.0 Operational Overview

- The system recognizes speech only while the VoiceFlight Activation Switch (VAS) is depressed.
- Upon depressing the VAS, do not begin speaking until the System Ready "Double Beep" is heard. If the "double beep" is not heard, release the switch and attempt to identify the problem.
- The VFS101 recognizes only words from the ICAO spelling alphabet, and only when they are used in the correct syntax. Using the wrong words, or in the wrong order will not work. The ICAO alphabet can be found in Section 5.2.
- If a speaking mistake is made, momentarily release the VAS, then depress it again before attempting to repeat the desired phrase.
- Audio output from the VFS101 stops upon VAS release. Prematurely releasing the VAS will prevent VFS101 Audio feedback, such as confirmation read-back of Direct-To commands.
- The VFS101 uses the aircraft position to improve speech recognition accuracy. Only waypoints within 250 nautical miles of the aircraft's current position or the last waypoint in the VFS101 flightplan will be eligible for recognition.
- The VFS101 is designed to recognize only the currently eligible waypoints. If an intended waypoint is repeatedly mis-recognized as some other waypoint, it is likely that the intended waypoint is not currently eligible. This could be a result of:
 - Missing "K" prefix on an airport name
 - An airway is active, and spoken waypoint is not located on that airway (Note: airports are never on airways)
 - Waypoint is located more than 250 NM from current search location
 - Waypoint is missing from VoiceFlight navigation database
- During initial familiarization with the VFS101 unit, some pilots have a tendency to release the VAS sooner, and more frequently, than is necessary. This tendency is quickly resolved as the pilot gains more experience with the unit.
- Upon entering a Direct-To waypoint, confirm that the correct identifier is displayed and the cross-track error is zero
- If the VFS101 or GPS units exhibit anomalous behavior turn off the VFS101 using the dedicated circuit breaker or power switch.
- The blinking cursor shown on the GPS does NOT represent VFS101 selection of a waypoint. The selection of a waypoint is shown by Asterisks surrounding the waypoint on the title line of Flightplan #19.

3.0 VFS101 Interconnect Diagram

The VFS101 system consists of a single 3.3 in x 5.5 in x 1 in, unit which is mounted behind the aircraft's instrument panel. This unit has a single DB-25 connector and connects to other aircraft systems as shown in the VFS101 System Block Diagram:

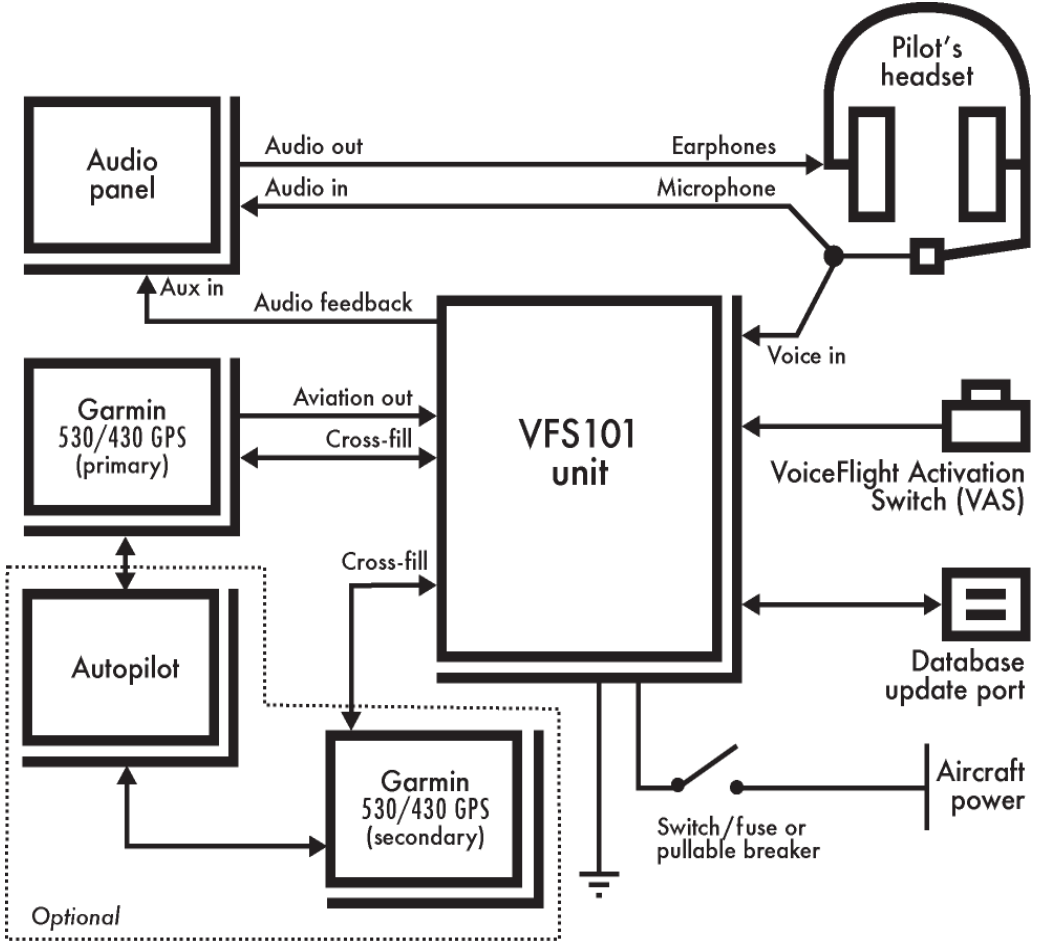

All waypoints input through the VFS101 appear on the primary GPS. The optional secondary GPS is connected to allow the pilot to continue to use the crossfill functionality to send flightplans from one GPS to the other.

The database update port is a standard USB jack which accepts USB flash storage devices, used to install new navigational data.

The Switch/fuse or pullable breaker can be used to disable the VFS101 in the event it exhibits anomalous behavior.

The VFS101 audio output is directly connected to the audio panel intercom system.

4.0 Getting Started

This section contains examples of how to enter Direct-To commands and a short Flightplan. If difficulties are encountered during any of the following exercises, please refer to the Trouble-Shooting section of this manual, consult with your authorized avionics installer, or contact VoiceFlight Systems technical support.

4.1 Cautions

- After depressing the VoiceFlight Activation Switch (VAS), do not begin speaking until the double-beep is heard.
- Confirm all Victor Airway expansions before activating the flightplan for use.
- Verify that Direct-to Waypoints are correct, and that no cross track error is shown on the NAV page.
- If the VFS101 or GPS unit exhibit anomalous behavior turn off the VFS101 using the dedicated circuit breaker or power switch.
- The VFS101 navigation database must be updated every 28 days in synchronization with the AIRAC charting cycle.
- The blinking cursor shown on the GPS does NOT represent VFS101 selection of a waypoint. The selection of a waypoint is shown by Asterisks surrounding the waypoint on the title line of Flightplan #19.

4.2 Pilot Qualification Procedure

The pilot qualification procedure is designed to confirm that the VFS101 is able to recognize a given pilot's voice and to familiarize the pilot with the system. Each pilot must complete pilot qualification before using the VFS101 for in-flight entry of navigational data.

Complete the procedures described in sections 4.3 and 4.4 twice each, once on the ground, and the second time in flight while flying under VFR conditions in an environment where the procedure can be safely completed. The qualification is complete when the procedures can be performed without errors.

4.3 Activating a Direct-To Waypoint

The VFS101 recognizes waypoints that are located with 250 nautical miles of the current aircraft position. For this exercise, select two or three nearby waypoints and record their identifiers exactly as would be used manually with the Garmin GPS units.

For illustration, this document uses two identifiers from the northeastern United States: Hartford-Brainard airport "KHFD" and the "SAGES"

navigational fix. You should select specific identifiers local to the current aircraft location.

It will be helpful for this initial example to jot down the ICAO alphabet translation for the selected identifiers. (The ICAO alphabet appears in the Functional Description section of this document, and on the VFS101 Quick Reference Card).

For our example in the northeastern U.S.:

KHFD -> Kilo Hotel FoxTrot Delta

SAGES -> Sierra Alpha Golf Echo Sierra

Note:

Initial familiarization is performed in a safely positioned stationary aircraft without the engine running.

Position the aircraft in a location where the GPS antenna have an unobstructed view of the sky. Apply power to the audio panel, the primary Garmin GPS unit, and the VFS101 unit.

Allow the GPS unit to complete its initialization and self-test. Acknowledge the initial test screens by pressing the ENT button. The VFS101 will complete its initialization before the GPS units are ready.

From the pilot seat, connect a standard aviation headset to the Pilot headset Jacks. Place the headset microphone close to your lips and adjust the audio panel for a comfortable volume.

Adjust the primary GPS unit to display the first Navigation page. This can be accomplished by depressing the CLR button for a full two seconds, as well as by a variety of other methods.

The VoiceFlight Activation Switch (VAS) is located on the pilot yoke and must be depressed when speaking to the VFS101 system. Examine the switch labels to confirm the VAS location. Always use extra caution to insure that the VAS is utilized, and not the transceiver Push-To-Talk switch.

Momentarily depress the VAS. A "double-beep" should be heard through the headset indicating that the VFS101 is operating and ready to recognize speech.

When utilizing the VFS101, never begin speaking unless the familiar system-ready "double-beep" is heard. Instead, release the VAS and attempt to determine the cause of the problem.

Attempt to initiate a Direct-To operation on the primary GPS using the selected sample waypoint. For illustration, this document uses KHFD. You should substitute an identifier near the current aircraft location.

1. Depress the VAS (and do not release it until instructed).
2. Clearly and distinctly say exactly the following words: (substituting a waypoint identifier near the current aircraft location)

"DIRECT" "KILO" "HOTEL" "FOXTROT" "DELTA" "ACTIVATE"

3. If the above words were properly entered, the VFS101 should immediately be playing an audio message confirming the entered waypoint. In the example this would be:
"Confirm Kilo Hotel Foxtrot Delta Direct ?"
4. If the stated waypoint is correct, promptly release the VAS and then immediately "Double Click" the VAS for confirmation (i.e. Depress and release the VAS TWICE in rapid succession).
5. If the "Double Click" was completed promptly, the GPS display should show the new Direct-To location at the bottom of the Navigation #1 page.
6. Always confirm that the correct waypoint identifier appears on the GPS and that the cross-track error (displayed immediately below) is zero (centered). If the aircraft were in flight, the aircraft would immediately begin navigating a new course to the specified waypoint.
7. Assuming that first waypoint was successfully entered, repeat the same procedure with the second waypoint that was selected above.
8. For additional familiarization, repeatedly switch the GPS Direct-To destination back and forth between the two waypoints several times until comfortable with the procedure.

4.3 Entering and activating a flightplan

Having successfully completed entry of Direct-To destinations, this section demonstrates the entry of entire Flight Plans. For this phase, select at least three nearby waypoints as described above.

For illustration in this document, KHFD, SAGES, and the Kingston VOR "IGN" will be used. You should substitute nearby waypoints (within 250 nm of the current aircraft location).

Entry and editing of flightplans are always performed in flightplan #19 of the catalog of stored flight plans on the primary GPS. This insures that VFS101 entries do not affect active navigation and allow the pilot an opportunity to review all of the waypoint entries before activation of the flightplan.

1. If necessary, re-apply power to the avionics equipment and initialize the GPS unit as described above.
2. Adjust the Primary GPS to display flightplan #19 from the catalog of stored flightplans. This is performed by:
 1. Depressing the "FPL" button
 2. Rotating the inner GPS knob one click clockwise
 3. Pushing the inner GPS knob -IN- (to activate the cursor)
 4. If necessary, rotating the outer GPS knob to select stored flightplan #19 (reserved for VoiceFlight use)
 5. Pressing the "ENT" button to display the flightplan

3. The title line shown at the top of flightplan #19 provides the best feedback on VFS101 status and operations. Since the VAS is currently inactive, the title line should read "--VOICE FLIGHT--".
4. Begin flight plan construction with the first sample waypoint. The identifier "KHFD" is used in this example. You should substitute a waypoint near the aircraft's current location.
5. Depress and hold the VAS until otherwise instructed.
6. Carefully speak the waypoint identifier, immediately followed by the word "ENTER" as shown below (substituting a local waypoint identifier):

"KILO" "HOTEL" "FOXTROT" "DELTA" "ENTER"
7. If the phrase was successfully recognized, a single "Beep" will be heard through the Pilot headset.
8. The recognized waypoint identifier will be displayed for reference on the flightplan title line and the waypoint will be added to the end of the flightplan.
9. Release the VAS. (It is not necessary to release the VAS between waypoints and is indicated here to allow the user an opportunity to prepare for the next waypoints.)
10. We will now add the second and third sample waypoints to the flightplan. For this example, it may be helpful to write down the ICAO translations before proceeding.
11. Depress and hold the VAS.
12. Carefully speak the second waypoint identifier, followed by the word "ENTER" as shown below (substituting a local waypoint identifier):

"SIERRA" "ALPHA" "GOLF" "ECHO" "SIERRA" "ENTER"
13. If correctly recognized, a single "Beep" will be heard.
14. Without releasing the VAS, enter the third waypoint identifier followed by the word "ENTER" (use a local waypoint identifier):

"INDIA" "GOLF" "NOVEMBER" "ENTER"
15. If correctly recognized, a single "Beep" will be heard.
16. Release the VAS and inspect the flightplan. All three of the sample waypoints should appear in sequence.
17. To familiarize yourself with the distinctive VFS101 error tone, depress the VAS and speak the word "ACTIVATE" by itself.
18. Examine the flightplan title line for feedback describing the error. The title line should display "NOT RECOGNIZED" for approximately two seconds. Release the VAS.
19. To illustrate simple error correction, depress the VAS and clearly speak "ERASE WAYPOINT".

20. If correctly recognized, a single "Beep" will be heard. The last waypoint in the flightplan ("IGN" in our case) will disappear from both the flightplan and the title line. Release the VAS.
21. It is not necessary to release the VAS between any of these commands. If the pilot observes a recognition error on the previous waypoint, he can simply speak "ERASE WAYPOINT" and then retry the previous waypoint entry.
22. For additional practice, clear the flightplan and re-enter all of the waypoints. Start by depressing and holding the VAS.
23. Carefully speak the words: "START" "NEW" "FLIGHTPLAN".
24. A single "Beep" should be heard and the entire contents of the flightplan should disappear. The flightplan will show only the initial "EMPTY" waypoint.
25. With the VAS still held, reenter all of the waypoints:
"KILO" "HOTEL" "FOXTROT" "DELTA" "ENTER"
"SIERRA" "ALPHA" "GOLF" "ECHO" "SIERRA" "ENTER"
"INDIA" "GOLF" "NOVEMBER" "ENTER"
26. Release the VAS.
27. Examine the flightplan entries and confirm that all of the sample waypoints were correctly entered.
28. After the flightplan has been entered, it can be activated for use by the following procedure:
 1. Depress the "MENU" button
 2. If necessary, rotate the outer GPS knob to select the "Activate Flight Plan?" entry.
 3. Press the "ENT" button to activate
29. The GPS will transfer the waypoints to the active flightplan and begin navigation of the new course.

5.0 Detailed Functional Description

This section describes in detail how to operate the VFS101 speech recognition system. For each behavior, a diagram shows the speech patterns used to activate the command. These diagrams are also shown on the VFS101 Quick Reference Card.

5.1 VoiceFlight Activation Switch (VAS)

The VFS101 speech-recognition system accepts speech input only when the VoiceFlight Activation Switch (VAS) is depressed. This switch is conventionally mounted on the left side of the pilot's yoke, and labeled VAS or VFS101.

Depressing the VAS should result in the pilot hearing a distinctive “double beep” sound through the aircraft audio system. This sound indicates the VFS101 system is active and awaiting input. Do not begin speaking until the double-beep is heard.

Releasing the VAS terminates all audio output from the VFS101 system, and discards any partial entry or extraneous noise. This behavior can be used in the event of a speech error to quickly clear the mistake and start over. Releasing the VAS also cancels any waypoint selections or incomplete airway entries.



5.2 ICAO Spelling Alphabet

The VFS101 uses the ICAO spelling alphabet (Alpha, Bravo, Charlie, etc.) for speech recognition. When using the VFS101 to input navigational information, be sure to use those words shown in the table below. Non-standard words (Adam, Billy, Fox, Ohh, etc.) will not be recognized.

ICAO Spelling Alphabet			
Alpha	Juliet	Sierra	Two
Bravo	Kilo	Tango	Three
Charlie	Lima	Uniform	Four
Delta	Mike	Victor	Fife
Echo	November	Whiskey	Six
Foxtrot	Oscar	X-Ray	Seven
Golf	Papa	Yankee	Eight
Hotel	Quebec	Zulu	Niner
India	Romeo	One	Zero

If you are having difficulty entering an airport waypoint remember that airport waypoints may be prefaced with a “K” (Kilo) in the continental United States, a “P” (Papa) in Alaska and Hawaii. Numbers must be entered as a string of digits e.g. “Fife Zero Niner”, not “five-hundred and nine”.

5.3 Direct-To

CAUTION: Waypoint and Track error must be verified on NAV page.

The VFS101 can be used to enter “Direct-To” waypoints. These appear on the primary navigation page of the Primary GPS, just as any other “Direct-To” waypoint would. The procedure for entering a “Direct-To” waypoint is shown in the following diagram:

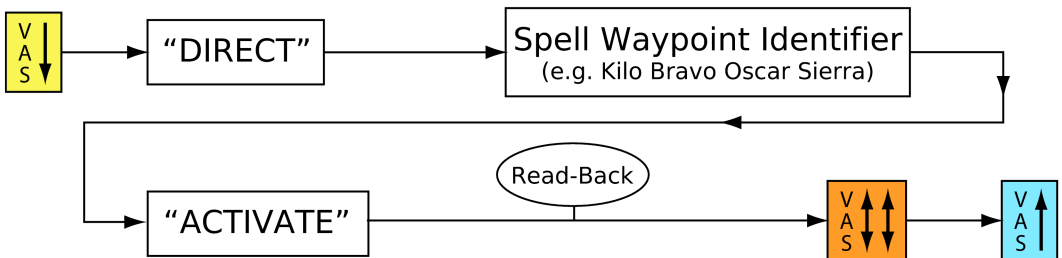

1. Turn to the Primary NAV page on the primary GPS.
2. Depress and hold the VAS.
3. Say “DIRECT”, then spell the desired “Direct-To” waypoint using the ICAO spelling alphabet, followed by the word “ACTIVATE”.

4. Instead of a beep, the VFS101 will play an audio read-back of the waypoint it recognized.
5. If and only if the read-back is correct, rapidly release and then double-click the VAS to confirm it.
6. On the Primary GPS, confirm that the entered waypoint appears as the "Direct-To" waypoint. Verify the Cross-Track error is zero.

5.4 Waypoint Entry

The VFS101 allows the pilot to enter waypoints into the primary GPS catalog of stored flightplans. The VFS101 uses saved FlightPlan #19 on the aircraft's primary Garmin GNS 430 or GNS 530. When the VFS101 and the primary GPS unit are powered up, the title of FlightPlan #19 will read "VOICE FLIGHT".

The Garmin GNS 430 and GNS 530 GPS units limit flightplans to 31 waypoints. Attempting to enter more than 31 waypoints in a flightplan via the VFS101 will result in an error tone being played through the audio system, and an error message appearing on the title line of FlightPlan #19 on the primary GPS.

If the VFS101 is exhibiting poor recognition, first make sure the pilot microphone is close to the lips, then try speaking more slowly. Be sure to speak clearly, pronouncing every syllable of each word. Leaving out a syllable, or running words together makes it more difficult for the VFS101 to understand pilot speech. Pay particular attention to fully enunciating the "t" sounds in words such as foxtrot, start, and flight (plan).

The following diagram illustrates the procedure for entering a waypoint:

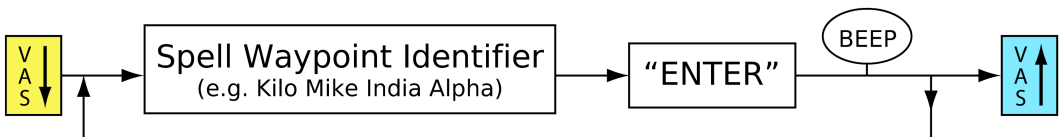

1. Turn to the VFS101 FlightPlan (Stored Flightplan #19) on the primary GPS.
2. Depress and hold the VAS. As usual a "double-beep" should be heard (not illustrated)
3. Spell a waypoint identifier using the ICAO phonetic alphabet, followed by the word "ENTER".
4. A single "beep" tone should be heard, indicating that the recognition has been successful. That the correct waypoint has been recognized can be verified by looking at the title line of the VFS101 FlightPlan. It will display the last two waypoints in the flightplan while the VAS is depressed.

For example if the last two waypoints entered were "ALB" and "KHFD" the title line would read:

ALB -> KHFD -> ?

- Additional waypoints may be entered if required, or the VAS may be released.

5.5 Error Correction

In the event a waypoint is incorrectly recognized, or if a mistake is made in waypoint entry the command “ERASE WAYPOINT” may be used to erase the last waypoint in the VFS101 FlightPlan (FlightPlan #19 on the primary GPS). The following diagram illustrates the process of erasing a waypoint:

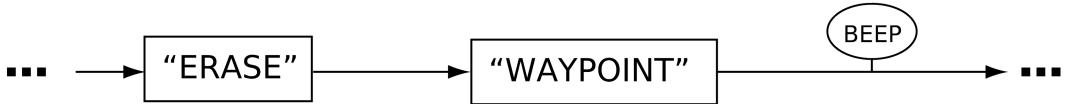

If a waypoint other than the final waypoint in FlightPlan must be erased, then see the “Advanced Editing” section of this manual.

5.6 Starting a new FlightPlan

To erase the contents of the VFS101 FlightPlan utilize the following diagram:

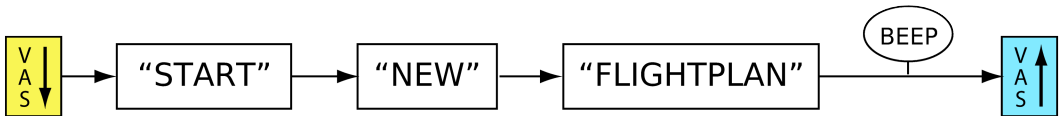

- Depress and hold the VAS.
- Say the words “START NEW FLIGHTPLAN”.
- Listen for the beep confirming that the speech command has been recognized.
- Verify that the contents of the VFS101 FlightPlan have been erased.
- Release the VAS, or begin entering waypoints into the now-empty FlightPlan.

5.7 Victor Airways

CAUTION: The sequence of waypoints generated for an airway must be carefully verified before the FlightPlan is activated.

The VFS101 is capable of expanding Victor Airways. The entry of a Victor Airway is valid only when there are one or more waypoints already in the VFS101 FlightPlan. If no waypoint has been selected, then the final waypoint in the VFS101 FlightPlan will be used as the waypoint where the Victor Airway will be entered. The process for entering a Victor Airway is shown in the following diagram:

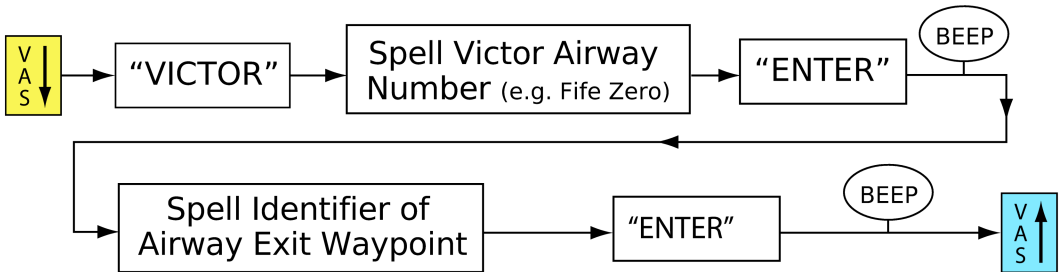

1. Adjust the Primary GPS to display Flightplan #19.
2. While the VAS is depressed, say "VICTOR", spell the number of the Victor Airway using the ICAO alphabet (i.e. Fife Zero Niner), then say "ENTER".
3. If the VFS101 generates a beep indicating successful recognition, verify the Victor airway was correctly recognized by looking at the title line of Flightplan #19. The line should show the entry waypoint and Victor airway number, followed by a question mark.
For example, if the entry waypoint was "BOS" and the Victor Airway entered was "VICTOR THREE" then the display should read:

BOS -> V3 -> ?

4. Enter the waypoint to exit the Victor Airway using the ICAO spelling alphabet, followed by the word "ENTER". Listen for the beep indicating successful recognition.
5. If this ends the flightplan, release the VAS, otherwise continue entering waypoints.
6. Before activating the VFS101 FlightPlan, verify that the Victor airway was correctly expanded by scrolling through it using the Primary GPS interface.

Releasing the VAS before an exit waypoint has been recognized will terminate the Victor airway entry.

Note: Garmin GNS 430 and GNS 530 GPS units are limited to 31 waypoints per FlightPlan. Some Victor Airway routes may be too long to be fully expanded. In the event such an entry is attempted the VFS101 will sound an Error Tone, display a warning message ("TOO MANY WAYPOINTS") on the title line of the VFS101 FlightPlan, and insert as many of the waypoints into the flightplan as possible.

5.8 Advanced Editing

In addition to adding waypoints to the end of the VFS101 FlightPlan it is possible to insert and delete waypoints elsewhere in the FlightPlan as well. The VFS101 editing system works by first selecting a waypoint in FlightPlan #19, then performing various editing operations at that point. To do this, first select the waypoint for modification according to the following diagram:

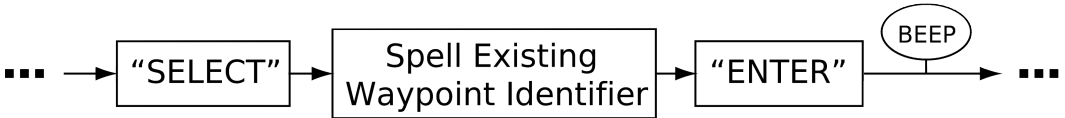

This will change the title line of the VFS101 flightplan to indicate that the waypoint has been selected. If (for example) you selected the waypoint “BOSOX” which was located after “BOS” in the FlightPlan, and before “ALB” the title line would read:

BOS -> *BOSOX* -> ALB

Any waypoints inserted will appear in the flightplan immediately before (above) the selected waypoint, allowing waypoints to be entered even at the start of the flightplan. Waypoints entered must be within 250 nautical miles of the waypoint preceding the selected waypoint (if the selected waypoint is not the first waypoint in the flightplan) or within 250 nautical miles of the aircraft's current GPS position (if the selected waypoint is the first waypoint in the flightplan). Victor Airways may be entered and will use the waypoint immediately preceding the selected waypoint as the airway entry waypoint. The “ERASE WAYPOINT” command will erase the selected waypoint, and select the waypoint immediately following (below) the erased waypoint. Releasing the VAS will terminate the selection of a waypoint.

Selection can also be used to erase multiple waypoints at a time, for example in the event of a major routing change. This is done using the “ERASE REMAINDER” command.

1. Turn to the VFS101 FlightPlan page on the primary GPS.
2. Depress and hold the VAS.
3. Select the last waypoint in the FlightPlan which is to be retained, using the “SELECT” command described above.
4. Say “ERASE REMAINDER” and listen for the single beep which indicates a command has been recognized.
5. Verify that the waypoints following the selected waypoint have been erased, then release the VAS before entering new flightplan segments.

6.0 Troubleshooting

This section describes some common error messages that may be generated by the VFS101, as well as solutions to some common problems.

- If the VFS101 does not respond to depressing the VAS, verify the VFS101 Circuit Breaker is closed, or the VFS101 Fuse is intact. If equipped with a dedicated power switch, confirm the switch is on.
- If the Primary GPS navigational database's cycle number (version) does not match the cycle of the navigational database on the VFS101 then an error message indicating this will be played through the audio system.
- When an error tone is heard from the VFS101, the title line of FlightPlan #19 on the primary GPS will briefly display a message describing the cause of the error.
- The VFS101 relies on location information from the primary GPS to function. If the VFS101 is not receiving location information from the primary GPS then the title line of flightplan #19 on the primary GPS will briefly display "NO GPS POS DATA" and the VFS101 will refuse to process speech commands. Examine the Primary GPS to determine if sufficient satellite coverage is available.
- If the VFS101 is not responding, and the title line of FlightPlan #19 on the Primary GPS reads *VFS101 SHUTDOWN*, then the VFS101 has seen too many VAS closures and openings without a successful recognition and has shut down for safety reasons. The VFS101 can be restarted by removing, then reapplying power using the VFS101 circuit breaker or switch.
- After the VAS has been depressed without issuing a single beep or error tone for 20 seconds, the VFS101 will terminate its recognition attempt and issue an error tone. A new speech entry cannot begin until the VAS has been released and depressed.
- If, instead of the expected waypoint the word "LOCKED" appears in FlightPlan #19 then the waypoint recognized is not in the Primary GPS's navigational database. This may be caused by an obsolete VFS101 database.
- If the VFS101 appears to be recognizing waypoint speech commands (by emitting a single beep after the command) but the results do not appear on the display, verify that the primary GPS is set to display FlightPlan #19 (-- VOICEFLIGHT --).
- If the steps above are unable to restore proper operation, disable the VFS101 unit (via dedicated circuit breaker or switch) and refer the unit to authorized maintenance personnel.

7.0 Settings and Maintenance

7.1 Volume Adjustment

If the volume level of the VFS101's audio output requires adjustment relative to other audio sources, the following procedures may be used. These procedures are only to be used while the aircraft is not moving.

To INCREASE the VFS101 audio output volume:

1. Plug a suitable aviation headset into the pilot headset jack.
2. With the aircraft audio panel, VFS101 and primary GPS powered up, enter a new title for stored flightplan #19 on the primary GPS containing the letter "U" (for UP) in the first character position and press ENT to install the new title. Briefly depress and release the VAS.
3. The title line will change to: "V <Volume Level 0-63> UP?" where the content in < > is replaced with a number indicating the current volume level.
4. Briefly press and release the VAS again. This will increase the volume by one step. A tone should be heard through the headset at the new volume level. Repeat until the volume is at the desired level.
5. Depress and hold the VAS for at least two seconds. This will return the VFS101 to normal operations, with the new volume output level.

To DECREASE the VFS101 audio output volume:

1. Plug a suitable aviation headset into the pilot headset jack.
2. With the aircraft audio panel, VFS101 and primary GPS powered up, enter a new title for stored flightplan #19 on the primary GPS containing the letter "D" (for DOWN) in the first character position and press ENT to install the new title. Briefly depress and release the VAS.
3. The title line will change to: "V <Volume Level 0-63> DOWN?" where the content in < > is replaced with a number indicating the current volume level.
4. Briefly press and release the VAS again. This will decrease the volume by one step. A tone should be heard through the headset at the new volume level. Repeat until the volume is at the desired level.
5. Depress and hold the VAS for at least two seconds. This will return the VFS101 to normal operations, with the new volume output level.

7.2 Updating the Navigational Database

It is necessary to update the VFS101 navigational database every 28 days in synchronization with the AIRAC charting cycle. These updates should be done at the same time that a new navigation data-card is installed in the Primary GPS (and secondary GPS if so equipped). If the VFS101 database is not current, some waypoints may be unavailable, and Victor Airway expansions may be incorrect.

It is the pilot's responsibility to ensure that the correct navigational data is installed on the VFS101. Failure to use current navigational data may result in incorrect Victor Airway expansion and an inability to enter some waypoints using the VFS101.

If the VFS101 navigational database and Primary GPS navigation database do not have the same cycle number, the VFS101 will play an audio warning message the first time the VAS is depressed after each time the unit is powered on. The VAS must remain depressed throughout the entire message to confirm the message has been heard or it will repeat. This warning ONLY indicates the GPS navigational database and the VFS101 navigational databases do not match. This could be the result of the VFS101 or the GPS navigational databases not being current.

The VFS101 is unable to identify the specific situation where both databases are non-current but have matching cycle numbers. The fact that the GPS database is not current will be evident on the GPS startup screens. If the GPS is subsequently updated without a matching update to the VFS101, aural messages will then be generated by the VFS101.

Operating the VFS101 with an obsolete navigational database is permissible, however doing so imposes an operational restriction:

If the navigational database installed on the VFS101 is not current, the pilot must manually verify the correctness of each waypoint and airway entered using the VFS101 by comparison to current navigational charts.

To update the VFS101 Navigational Database, utilize the following procedure:

1. Insert the supplied USB flash drive into a USB port on a computer running a recent version of Microsoft Windows, Apple OS X, or Linux. On most systems the flash drive should be automatically mounted by the operating system. Remove any files or directories that remain on the USB flash drive.
2. Download the latest navigational database from the "Navigation Update" section of the VoiceFlight Systems website (<http://www.voiceflight.com>) into the root directory of the USB Flash Drive. If the website is unavailable, please contact VoiceFlight systems customer support at (518)-276-3364 for assistance.
3. After the download is complete, eject the USB flash drive and remove it from the computer's USB port.

4. At the aircraft, plug a suitable aviation headset into the pilot's headset jacks so that audio responses from the VFS101 can be heard. Alternatively, the aircraft's cockpit speaker may be utilized.
5. With the Aircraft stationary, apply power to the aircraft audio panel and the VFS101. Wait at least thirty seconds for the VFS101 to initialize before inserting the USB flash drive into the VFS101 USB jack.
6. Wait at least one additional minute for the update to be performed, then depress and hold the VAS. The audio message "Navigation Update Complete" should be heard immediately through the audio system. If the audio message is not heard wait, release the VAS and wait another full minute and before depressing the VAS again. If the message is still not heard, remove the USB drive, remove power from the units and repeat steps 4 & 5.
7. Remove the USB flash drive from the VFS101 USB jack.
8. Install a navigational database data-card with the matching cycle number into the primary GPS (and secondary GPS if so equipped). Apply power to the GPS(s), wait for them to initialize, and acknowledge their self-test screens as required.
9. Verify that the updates have resulted in congruent database cycle numbers for both the VoiceFlight and Garmin systems by depressing and holding the VAS. If a simple error tone or double beep is heard, without the explicit aural message "WARNING Navigation data is not current", then the VFS101 has determined that the navigational databases have matching cycle numbers.

* An error tone may be heard if the navigation update is performed in a hanger and GPS position data is not available to the VFS101. However, this situation does not interfere with the update, or the explicit warning when the navigation databases do not match.

7.3 Configuration Display Mode

The Configuration Display Mode is used to display the current volume setting, the part numbers and checksums of the software installed on the VFS101, and the part number and checksum of the installed navigational database. The procedure described here should not be used while the aircraft is moving:

1. Enter a new title for stored flightplan #19 on the primary GPS containing the letter "C" in the first character position and press the "ENT" button to confirm the new title. Briefly depress and release the VAS.
2. The VFS101 will enter Configuration Display Mode. The title line of Flightplan #19 will be re-written to display the current VFS101 volume setting. By quickly pressing and releasing the VAS, the next configuration item will be displayed. The following table shows the order of the configuration items displayed, and the content shown on the title line for each item.

#	Description	Displayed on Title Line
1	Current Volume Setting	V <Volume setting 0-63>
2	Navigational Database Cycle/Date	DB <Cycle/Date>
3	Navigational Database checksum	DC <Checksum>
4	Recognition Processor Software part number	RP <Part Number>
5	Recognition Processor Software checksum	RC <Checksum>
6	Interface Processor Software part number	IP <Part Number>
7	Interface Processor Software checksum	IC <Checksum>

3. Press and holding the VAS for two seconds. This will cause the VFS101 to exit configuration display mode.

8.0 Limited Warranty

VoiceFlight Systems LLC warrants its new products and parts against defects in material and/or workmanship for two years from the date of purchase. During this period, VoiceFlight Systems LLC will, at its sole option, repair or replace defective product or parts without charge to you, excluding shipping.

The warranties and remedies contained herein are exclusive and in lieu of all other warranties express or implied or statutory, including any liability arising under any warranty of merchantability or fitness for a particular purpose, statutory or otherwise. This warranty gives you specific legal rights, which may vary from state to state.

IN NO EVENT SHALL VOICEFLIGHT SYSTEMS LLC BE LIABLE FOR ANY INCIDENTAL, SPECIAL, INDIRECT OR CONSEQUENTIAL DAMAGES, WHETHER RESULTING FROM THE USE, MISUSE, OR INABILITY TO USE THIS PRODUCT OR FROM DEFECTS IN THE PRODUCT. Some states do not allow the exclusion of incidental or consequential damages, so the above limitations may not apply to you.

VoiceFlight Systems LLC retains the exclusive right to repair or replace the unit or software or offer a full refund of the purchase price at its sole discretion. Such remedy shall be your sole and exclusive remedy for any breach of warranty.

To obtain warranty service contact VoiceFlight Systems customer service at:

VoiceFlight Systems, LLC
1223 Peoples Avenue
Troy, NY 12180
Telephone: (518) 276-3364

Appendix A: Packing List

As shipped, the VFS101 system (VFS101-KIT001) includes the following items:

- VFS101, The VFS101 unit
- VFS101-Z001, USB mass storage drive (“thumb drive”) with VoiceFlight Logo
- VFS101-INSISTR, VFS101 Installation Instructions
- VFS101-PMAN, VFS101 Pilot's Flight Manual Supplement
- VFS101-QRC, VFS101 Pilot's Quick Reference Card

The optional VFS101 Installation Accessory kit (VFS101-KIT002) includes:

- VFS101-CA004, USB Jack and cable assembly
- VFS101-M007, USB jack mounting plate
- Two 4-40 screws for affixing the mounting plate

Appendix B: VFS101 Aural Messages

Confirm <Waypoint Name> Direct

Pilot requested Direct-To a specified waypoint. VFS101 is awaiting VAS Double-Click to confirm recognized waypoint.

Warning: Navigation Data Is Not Current

Navigation database currently installed in VFS101 does not match navigation database card installed in Primary GPS.

Navigation Update Complete

Previous update of VFS101 navigation database was successfully completed.

Software Update Complete

Previous update of VFS101 operational software was successfully completed.

VoiceFlight Disabled

VFS101 operations terminated after five successive attempts without successful recognition. Unit remains inactive until next Power Cycle.

Appendix C: VFS101 Title Line Messages

NOT RECOGNIZED	Spoken phrase was not recognized as valid command or eligible waypoint.
INVALID ON AIRWAY	VFS101 is expecting exit waypoint for airway.
NOT WITH SELECTION	DIRECT-TO is not valid while waypoint is selected.
VAS WAS RELEASED !	VAS was released before Direct-To confirmation could be requested.
NO PRIOR WAYPOINT	When waypoint is selected, airway entry begins with (and requires) preceding waypoint.
SELECTION REQUIRED	ERASE REMAINDER command requires a previously selected waypoint.
TOO MANY WAYPOINTS	Garmin GPS FlightPlan is full (31 waypoints).
NO DOUBLE CLICK !	Direct-To waypoint was not confirmed by prompt double-click of VAS.
- WAITING TOO LONG -	VAS depressed for 20 seconds without successful recognition. Release VAS before continuing.
NO GPS POS DATA	VFS101 is not receiving valid position data from the GPS. Check satellite signal reception.
* VFS101 SHUTDOWN *	Five successive attempts without any successful recognition. VFS101 operations terminated until next Power Cycle.